CI13322 Datasheet

High performance neural network intelligent voice chip



• Neural Network Processor (BNPU)

-BNPU V3.5 supports DNN\TDNN\RNN\CNN and other neural networks and parallel vector operations, this processor can realize high-performance speech recognition and speech noise reduction functions

• CPU and memory

-CPU frequency up to 210 MHz
-Built-in 2MBytes Flash memory
-Built-in 288KBytes SRAM
-Built-in 256bit eFuse for application encryption

• Audio Codec

-High performance and low power consumption audio ADC, SNR \geq 95dB
-Low power consumption audio DAC, SNR \geq 95dB

• PWM

-Supports 4 PWM interfaces
-Supports 1 EPWM

• GPIO

-19 high-speed GPIO with a flip frequency up to 20MHz
-11 GPIO supports 5V input

• Reset and power management

-Power supply voltage range 3.6V~5.5V
-Built-in PMU power management unit
-Built-in power-on reset (POR)
-Built-in voltage detection (PVD)

• Clock

-Built-in RC oscillator
-Support for external crystal oscillator input

• Communication interface

-1 IIC interface
-3 UART interfaces, support 5V communication, support up to 3Mbps rate

• Timer and watchdog

-Built-in 2 sets of 32-bit timers and 1 watchdog

Catalogue

1 Overview	7
1.1 Function Description	7
1.2 Chip Specifications	8
2 Pin diagram and function description	10
2.1 Pin diagram	10
2.2 Pin description	11
2.3 Multiplexing function	14
3 Chip interface description	14
3.1 General Input Output (GPIO)	14
3.1.1 Introduction	14
3.1.2 Characteristics	14
3.2 Universal Asynchronous Receiver Transmitter (UART)	15
3.2.1 Introduction	15
3.2.2 Characteristics	15
3.2.3 Schematic diagram	16
3.3 Pulse Width Modulation output (PWM)	16
3.3.1 Introduction	16
3.3.2 Characteristics	17
3.4 Universal Timer (TIMER)	17
3.4.1 Introduction	17
3.4.2 Characteristics	17
3.5 Audio Digital Transmission Bus (IIS)	18
3.5.1 Introduction	18
3.5.2 Characteristics	18
3.6 Integrated Circuit Bus (IIC)	19
3.6.1 Introduction	19
3.6.2 Description of characteristics	20
3.6.3 Schematic diagram	20
3.7 Independent Watchdog (IWDG)	21
3.7.1 Introduction	21

- 3.7.2 Characteristics21
- 3.8 Multimedia Audio Codec (CODEC)21
 - 3.8.1 Introduction21
 - 3.8.2 Characteristics22
- 3.9 Enhanced Pulse Width Modulation output (EPWM)22
 - 3.9.1 Introduction22
 - 3.9.2 Characteristics22
 - 3.9.3, Configuration value description23
 - 3.9.4 Counting patterns23
 - 3.9.5 Method of use 23
- 4 Electrical Characteristics 24
- 5 Packaging information25
- 6. Order information 26
- Application Programme27
 - 7.1 Refer to circuit diagram for application27
 - 7.2 Application of other precautions29
- 8 Revision history 29

Figures

Figure 1: Chip function block diagram	8
Figure 2: QFN32 pin diagram	10
Figure 3: Data frame timing diagram 1	16
Figure 4: Data frame timing diagram 2	16
Figure 5: Data frame timing diagram 3	16
Figure 6: Schematic diagram of channel merging function	19
Figure 7: Continuous data write operation timing diagram	20
Figure 8: Write before read operation timing diagram	21
Figure 9: IIC read operation timing diagram	21
Figure 10: Packaging size	25
Figure 11: CI1332X typical application solution reference circuit diagram	27
Figure 12: Furnace temperature curve Figure	29

Table of Contents

Table 1: Pin Description	11
Table 2: IO multiplexing function	14
Table 3: Electrical characteristics Table	24
Table 4: Order Information Table	26
Table 5: CI1332X Upgrade Mode Table	28
Table 6: Revision history	29

1 Description

1.1 Functional description

CI13322 is a third-generation high-performance neural network intelligent voice chip developed by Chipintelli. It integrates the company's proprietary Brain Neural Network Processor (BNPU) V3.5 and CPU core, delivering a system clock rate of up to 210MHz. The chip features 288KB of built-in SRAM, a PMU power management unit, and an RC oscillator. It incorporates a single-channel high-performance, low-power Audio Codec along with multiple peripheral control interfaces including UART, I2C, PWM, and GPIO. With minimal external components like resistors and capacitors, this chip enables flexible hardware solutions for various intelligent voice products, offering exceptional cost-effectiveness.

CI13322 uses industrial-grade design standards, has high environmental reliability, the chip operating temperature range is between -40°C and +85°C, complies with MSL3 level humidity sensitivity rating, complies with IEC 61000-4-24KV contact discharge test standard, complies with FCC electromagnetic compatibility standard, complies with ROHS and REACH environmental protection standard.

The CI13322 utilizes Chipintelli's 3.5th-generation BNPU technology, which supports neural networks including DNN, TDNN, RNN, and CNN, along with parallel vector operations. This enables high-performance speech recognition, noise reduction, and exceptional environmental noise suppression capabilities. The CI13322 solution also supports multiple global languages such as Chinese, English, and Japanese, making it widely applicable in home appliances, lighting, toys, wearables, industrial equipment, and automotive sectors. It facilitates voice interaction control and supports various intelligent voice application scenarios.

1.2 Chip specifications

The function block diagram of CI13322 chip is shown in the figure below:

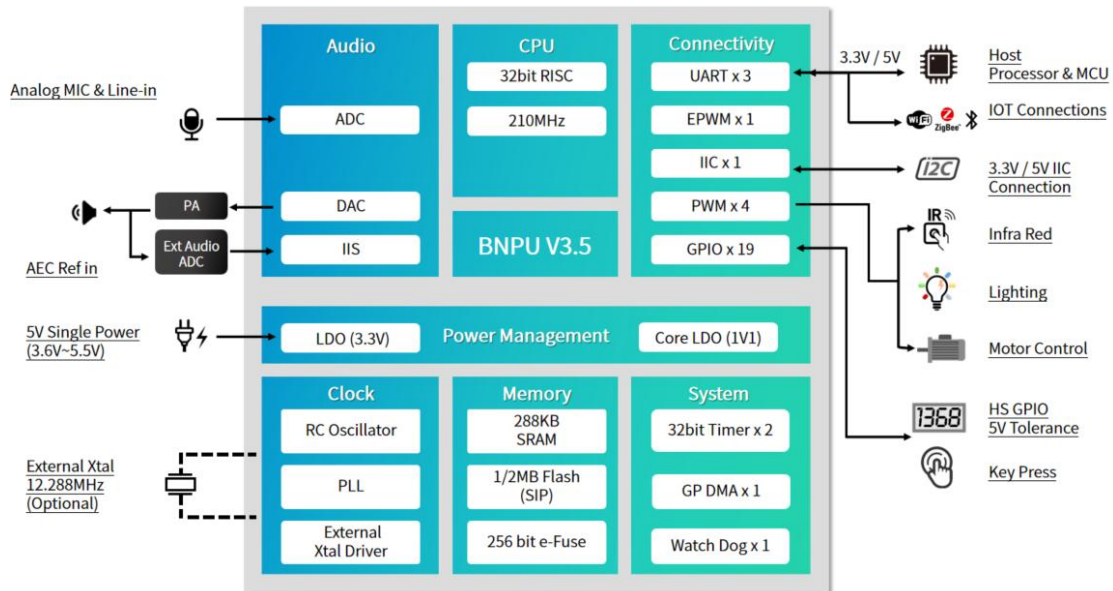

Figure 1: Chip function block diagram

■ Brain neural network processor BNPU V3.5

-BNPU V3.5 supports DNN,TDNN,RNN,CNN and other neural networks, parallel vector operations, and can realize high-performance speech recognition, speech noise reduction and other functions

■ CPU

- 32-bit high-performance CPU, running at up to 210MHz
- 32-bit single-cycle multiplier, supporting DSP expansion acceleration

■ Memory

- Built-in 288KB SRAM
- Built-in 256bit eFuse
- Built-in 2MB Flash

■ Audio interface

- Built-in high performance low power Audio Codec module, supporting single channel ADC sampling and single channel DAC playback
- Support for Automatic Level Control (ALC) function
- Support for 8kHz/16kHz/24kHz/32kHz/44.1kHz/48kHz sampling rate

■ Power management unit PMU

-Built-in 2 high performance LDO, no additional power chip is required, and only a small number of capacitors are required on the periphery

-Supports 5V direct input power supply, with a minimum power supply range of 3.6V and a maximum power supply range of 5.5V

■ **Clock**

-Built-in RC oscillator

■ **Peripheral and timer**

-3 UART ports, up to 3M baud rate

-1 IIC interface, which can be expanded by external IIC devices

-4 PWM interfaces, which can be directly driven for lamp control and motor applications

-1 EPWM complementary PWM for lamp control and motor applications

-2 built-in 32-bit timers

-Built-in 1 independent watchdog (IWDG)

■ **GPIO**

-Supports 19 GPIO ports and can be used as a master control IC

-Each GPIO port can be configured with interrupt function, and support pull-up and pull-down configuration

-11 GPIO supports wide voltage 5V level signal direct communication, no need to external level conversion, only need to external pull up to 5V resistor

■ **Software development support**

-Provides complete software development kit, application solution examples and voice development platform online firmware production functions, details please visit:

<https://aiplatform.chipintelli.com>

■ **Firmware flashing and protection**

-Support UART upgrade and firmware protection

■ **EMC and ESD**

-Internal ESD enhanced design, can pass 4KV contact discharge test

■ **ROHS and REACH**

-Use of environmentally friendly materials, support through ROHS and REACH tests

■ **Packaging and operating temperature range**

-Packaging form: QFN32, 4mmX4mmX0.75mm

-Working environment temperature: -40°C to 85°C

2 Pin diagram and function description

2.1 Pin diagram

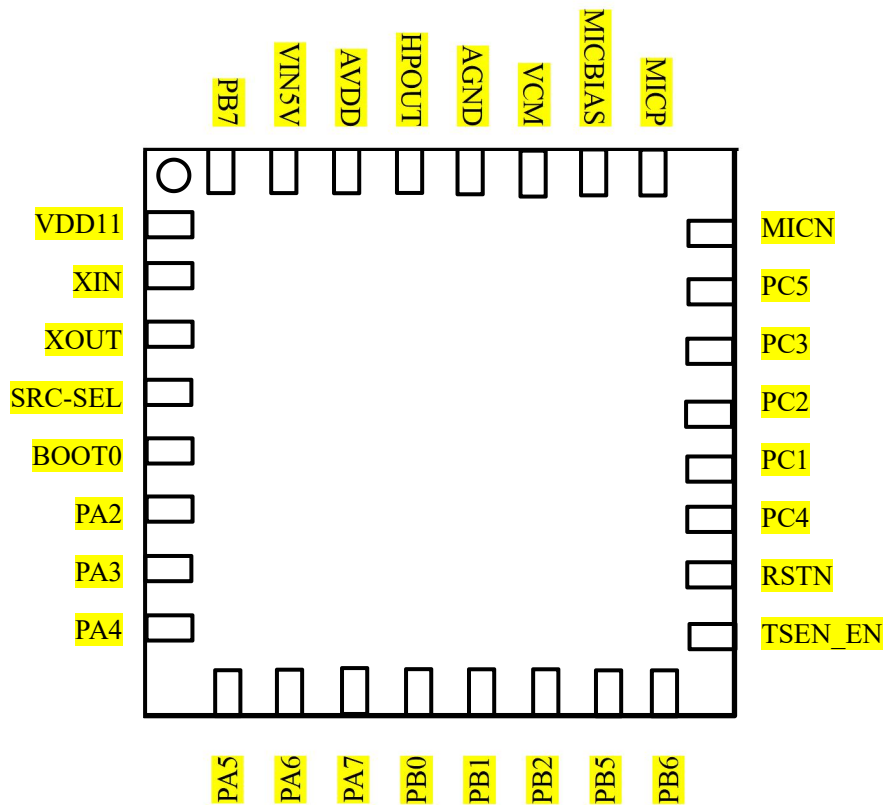

Figure 2: QFN32 pin diagram

2.2 Pin description

Table 1: Pin description

Pin number	Pin Name	Type	5V-- Tolerant	Power on default state	Description Alternate functions
1	VDD11	P	-	-	<ul style="list-style-type: none"> ● LDO-1.1V output ● The kernel is powered by 1.1V input * Note1*
2	XIN	I	-	-	<ul style="list-style-type: none"> ● XIN (default state of power-on) ● GPIO PA0 ● PWM2
3	XOUT	O	-	-	<ul style="list-style-type: none"> ● XOUT (default on power-on state) ● GPIO PA1
4	SRC_SEL	I	-	IN, T+U	<ul style="list-style-type: none"> ● Debug clock selection is NC by default
5	BOOT0	I	-	IN, T+U	<ul style="list-style-type: none"> ● Debug start mode is selected by default NC
6	PA2	IO	√	IN, T+D	<ul style="list-style-type: none"> ● GPIO PA2 (default state on power-on) ● IIS_SDI ● IIC_SDA ● UART1_TX ● PWM0 ● PWMP
7	PA3	IO	√	IN, T+D	<ul style="list-style-type: none"> ● GPIO PA3 (default on power-on state) ● IIS_LRCLK ● IIC_SCL ● UART1_RX1 ● PWM1 ● PWMN
8	PA4	IO	√	IN, T+U	<ul style="list-style-type: none"> ● GPIO PA4 (default on power-on state)/PG_EN (programming function is activated when high on power-on) ● IIS_SDO ● - ● - ● PWM2 ● PWMP
9	PA5	IO	√	IN, T+D	<ul style="list-style-type: none"> ● GPIO PA5 (default on power-on state) ● IIS_SCLK ● - ● UART2_TX ● PWM3 ● PWMN
10	PA6	IO	√	IN, T+D	<ul style="list-style-type: none"> ● GPIO PA6 (default on power-on state) ● IIS_MCLK ● - ● UART2_RX ● PWM0
11	PA7	IO	√	IN, T+D	<ul style="list-style-type: none"> ● GPIO PA7 ● PWM0 ● TX1 ● INT0
12	PB0	IO	√	IN, T+D	<ul style="list-style-type: none"> ● GPIO PB0 ● PWM1 ● RX1

					<ul style="list-style-type: none"> ● INT1
13	PB1	IO	√	IN, T+D	<ul style="list-style-type: none"> ● GPIO PB1 ● PWM2 ● TX2 ● PWMP
14	PB2	IO	√	IN, T+D	<ul style="list-style-type: none"> ● GPIO PB2 ● PWM3 ● RX2 ● PWMN
15	PB5	IO	√	IN, T+U	<ul style="list-style-type: none"> ● GPIO PB5 (default state on power-on) ● UART0 TX ● IIC SDA ● PWM1 ● PWMP
16	PB6	IO	√	IN, T+U	<ul style="list-style-type: none"> ● GPIO PB6 (default state on power-on) ● UART0_RX ● IIC_SCL ● PWM2 ● PWMN
17	TEST_EN	I	-	IN, T+U	<ul style="list-style-type: none"> ● The test enable pin is set to NC by default
18	RSTN	I	-	IN, T+D	<ul style="list-style-type: none"> ● Reset pin, low level reset, default NC
19	PC4	IO	-	IN, T+U	<ul style="list-style-type: none"> ● Retained (default state on power-on) ● GPIO PC4 ● SCL ● PWM0
20	PC1	IO	-	IN, T+D	<ul style="list-style-type: none"> ● Retained (default state on power-on) ● GPIO PC1 ● 3.TX2 ● PWM3
21	PC2	IO	-	IN, T+U	<ul style="list-style-type: none"> ● Retained (default state on power-on) ● GPIO PC2 ● RX2 ● PWM2
22	PC3	IO	-	IN, T+D	<ul style="list-style-type: none"> ● Retained (default state on power-on) ● GPIO PC3 ● SDA ● PWM1
23	PC5	IO	-	IN, T+D	<ul style="list-style-type: none"> ● GPIO PC5 ● BOOT1 Select the startup mode. NC is the functional mode when power-on.
24	MICN	I	-	-	Microphone N input
25	MICP	I	-	-	Microphone P input
26	MICBIAS	O	-	-	Microphone bias output
27	VCM	O	-	-	VCM Output
28	AGND	P	-	-	Analog ground
29	HPOUT	O	-	-	DAC output
30	AVDD	P	-	-	<ul style="list-style-type: none"> ● Internal LDO-3.3V Output ● Internal analog circuitry is powered by 3.3V input ● * Note1 *
31	VIN5V	P	-	-	<ul style="list-style-type: none"> ● Power supply voltage input, power supply voltage range 3.6V~5.5V

					* Note1*
32	PB7	IO	-	IN, T+U	● GPIO PB7
33	GND	P	-	-	Ground

Note1 The pin needs to be connected to an external 4.7uF capacitor

Note2 When power on, this pin is high level, and the system will enter programming mode

Symbol definition

I input

O output

IO bidirectional

P power or ground

T+D Tri-state pull-down

T+U Tri-state pull-up

OUT power-on defaults to output mode

IN power-on defaults to input mode

All IOs can be configured with drive capability and pull-up/down status.

2.3 Function multiplexing

Table 2: IO multiplexing function

Pin Name	Function1	Function2	Function3	Function4	Function5	Function6	Specific Function
XIN	PA0	PWM2					XIN
XOUT	PA1						XOUT
PA2	PA2	SDI	IIC_SDA	UART1_TX	PWM0	PWMP	
PA3	PA3	LRCK	IIC_SCL	UART1_RX	PWM1	PWMN	
PA4	PA4	SDO	-	-	PWM2	PWMP	PG_EN Note1
PA5	PA5	SCLK		TX2	PWM3	PWMN	
PA6	PA6	MCLK		RX2	PWM0		
PA7	PA7	PWM0	TX1	INT0			
PB0	PB0	PWM1	RX1	INT1			
PB1	PB1	PWM2	TX2	PWMP			
PB2	PB2	PWM3	RX2	PWMN			
PB5	PB5	UART0_TX	IIC_SDA	PWM1	PWMP		
PB6	PB6	UART0_RX	IIC_SCL	PWM2	PWMN		
PC4	-	PC4	SCL	PWM0			
PC1	-	PC1	TX2	PWM3			
PC2	-	PC2	RX2	PWM1			
PC3	-	PC3	SDA	PWM1			

Note 1: The PA4 (PG_EN) pin is internally pulled up by default. When the power-on status is detected as high, the chip automatically enters upgrade mode upon detecting an upgrade signal on UART0 during power-on. In this state, the accompanying upgrade tool can be used to program the internal Nor Flash memory. If no upgrade signal is detected on UART0, the system will return to normal operation mode.

3 Chip interface description

3.1 General Input Output (GPIO)

3.1.1 Brief introduction

GPIO (General IO Interface) is a general-purpose input/output port that allows devices to interact with peripheral hardware at level signals. It can be used as an input to receive external signals or as an output to control peripheral hardware.

3.1.2 Characteristic

The CI13322 chip supports multiple programmable I/O pins (configurable through software individually). Each GPIO port is equipped with corresponding control and configuration registers, enabling precise control and status monitoring of peripheral hardware by independently activating or deactivating individual pins. The chip features three GPIO groups: GPIO0 (corresponding to the PA port), GPIO1 (corresponding to the PB port), GPIO2 (corresponding to the PC port), and GPIO3 (corresponding to the PD port). For detailed pin assignments for each group, please refer to Section 2.2 Pin Descriptions.

CI13322 provides a series of interfaces including IO input/output status query, interrupt shielding, interrupt shielding status check, interrupt clearing, interrupt status inquiry, and interrupt trigger mode configuration (supporting low-level, high-level, rising-edge, falling-edge, or both-edge triggering) to meet diverse application scenarios and requirements.

3.2 Universal Asynchronous Receiver Transmitter (UART)

3.2.1 Brief introduction

UART is a universal asynchronous serial communication data interface that enables data reception and transmission between two devices, supporting full-duplex communication. There is no shared clock signal between the receiving and sending devices. To ensure communication reliability, both devices need to set the same baud rate and data frame format.

CI13322 supports 3 UART controllers: UART0, UART1 and UART2.

3.2.2 Characteristic

- Supports the standard UART protocol. The data frame format consists of four parts: start bit, data bit (length can be configured), parity bit (optional) and stop bit (width can be configured). The baud rate can be configured.
- When the bus is idle, the signal line is high.
- Start: used to identify the start of a data frame. Each data frame starts with an output of a bit width low level from the sender to notify the receiver that data transmission has started;

- Data bit: The length of the transmitted data can be configured by UART_LCR register to 5~8 bits, usually 8 bits. The bit transmission order is low priority, sending the lowest bit LSB first and the highest bit MSB last;
- Parity check: The parity check function can be enabled or disabled through the UART_LCR register. When the parity check function is enabled, the parity check can detect whether there is an error in data transmission after the completion of data bit transmission;
- Stop bit: used to identify the end of the transmitted data frame. Each data frame ends with a high level, and the length can be configured as 1, 1.5, or 2 bits through UART_LCR register;

3.2.3 Sequence chart

The timing diagram of UART data transmission of one data frame (8-bit data bit, parity bit, 1bit stop bit) is as follows:

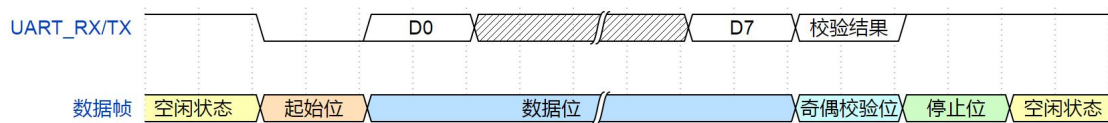

Figure 3: Data frame timing diagram 1

The timing diagram of UART data transmission of one data frame (start bit, 7-bit data bit, parity bit, 1.5bit stop bit) is as follows:

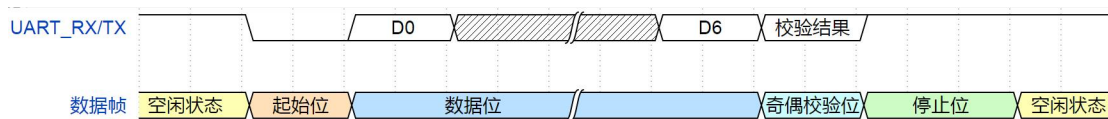

Figure 4: Data frame timing diagram 2

The timing diagram of UART data transmission of one data frame (start bit, 8-bit data bit, no parity bit, 2-bit stop bit) is as follows:

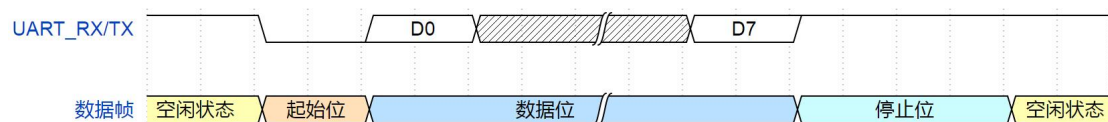

Figure 5: Data frame timing diagram 3

The higher the UART baud rate is set, the faster the data transmission speed will be, but it will also increase the interference and bit error rate. When setting the baud

rate, we need to consider whether the serial port hardware of both sides of communication supports this baud rate. If the baud rate is set too high, the data transmission may be unstable.

Supports a maximum baud rate of 3Mbps, which can be configured through UART_I_BRD and UART_F_BRD registers.

3.3 Pulse width modulation output (PWM)

3.3.1 Brief introduction

PWM (Pulse Width Modulation) is a technology that simulates the level of analog signal by adjusting the duty ratio (the proportion of high level time to the whole cycle) of digital pulses. It is widely used in motor control, power supply management, LED dimming and other fields.

CI13322 has 4 dedicated PWM. The frequency of each PWM output signal is configured by timer SC register, and the duty cycle of each PWM output signal is configured by timer SPWMC register. 100% duty cycle (often high) is not supported. If 100% duty cycle is required, it can be implemented by configuring GPIO.

3.3.2 Characteristic

- Counting clock division, supporting 1, 2, 4 and 16 division, which can be configured through timer cfg register;
- Supports two 32-bit decrement counters;
- Variable duty cycle PWM pulse width waveform output;
- The output level polarity after support stop is configured through timer restart MD register;

3.4 General Timer (TIMER)

3.4.1 Brief introduction

The Timer (GENERAL-TIMER) is a 32-bit decrementing counter featuring configurable frequency division and multiple counting modes. It triggers a timing event when the count reaches zero, commonly used to repeatedly trigger timer events within specified time intervals. This component can serve as both a periodic interrupt

generator and event counter. The CI13322 chip contains two identical dedicated timers (TIMER0~TIMER1), supporting cascaded Timer functionality.

3.4.2 Characteristic

- Supports three counting modes, which can be configured through the timer_CFG register: single-cycle counting mode, automatic reload counting mode and free running counting mode;
 - Single-cycle counting mode: The timer counts only one counting cycle;
 - Automatic reload count mode: The counter is reinitiated at the end of each count;
 - Free running count mode: The count value cycles from 0xFFFFFFFF to 0x00000000 at the end of each count;
- Counting clock division, supporting 1, 2, 4 and 16 division, which can be configured through timer cfg register;
- 32-bit decrementing counter, which can read the real-time value of the counter and read it through the timer CC register;
- Supports cascaded mode configuration, which is configured through timer cfg0 register;
- Support interrupt when counting is completed and reported;

3.5 Audio Digital Transmission Bus (IIS)

3.5.1 Brief introduction

IIS is a communication interface used to transmit audio data between digital audio devices, and realizes the signal transmission function of external 16/20/24/32bit stereo digital audio signal codec circuit.

The CI13322 features three IIS channels: IIS0 through IIS2. Specifically, IIS0 serves as a general-purpose IIS with both TX (transmission) and RX (reception) units, enabling communication with other chips via PAD. IIS1 functions as an internal dedicated IIS for the chip, containing TX and RX units specifically designed for the CI13322's internal CODEC DAC and ADC respectively. IIS2 is a specialized IIS channel exclusively for RX functionality.

CI13322 supports dedicated IISDMA for data transfer between memory and IIS. All IIS share a single IISDMA0, and each IIS uses a different channel of IISDMA0.

3.5.2 Characteristic

- The IIS interface is composed of MCLK, SCK, LRCLK, SDI and SDO signal lines;
- MCLK: The main clock, which is usually 128/192/256/384 times of the audio sampling rate (the frequency of LRCLK);
- SCK: serial bit clock, 1bit data is transmitted in each SCK cycle;
- LRCLK: Frame clock, used to switch data between left and right channels;
- In IIS format, LRCLK is 0 to indicate that the current data frame is left channel data, and 1 to indicate that the current data frame is right channel data;
- In left/right alignment format, LRCLK is 0 to indicate that the current data frame is right channel data, and 1 to indicate that the current data frame is left channel data;
- SDI/SDO: serial data input/output, used to transmit audio data;
- The ratio of LCLK to SCK can be configured to 1:32 or 1:64 through the IISRX0CTRL/IISTX0CTRL registers;
- The data format can be configured as IIS format, left aligned format and right aligned format through IISRX0CTRL/IISTX0CTRL registers;
- The number of bits for sending and receiving data can be configured as 16bit, 20bit, 24bit and 32bit through IISRX0CTRL/IISTX0CTRL registers;
- In single-channel mode, the function of copying channel data is supported. When sending, the single-channel data is sent to both left and right channels at the same time, and when receiving, the left and right channels are merged into single-channel data;
- When the sampling data bit width is 16bit, the channel data merging function is supported. The specific functional principle is shown in the figure below;

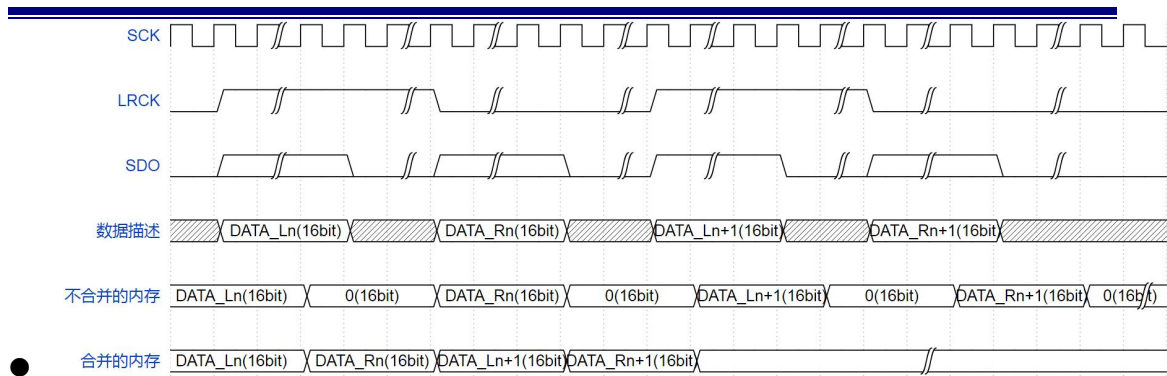

Figure 6: Schematic diagram of channel merging function

- When receiving and sending data, the left and right channel data support switching. The switching of received left and right channel data is configured through IISRX0CTRL register, and the switching of sent left and right channel data is configured through IISTX0CTRL register;
- The data receiving and sending channels are completely independent;
- Supports silent mode, which is configured through IISRX0CTRL register for receiving and IISTX0CTRL register for sending;
- Supports the configuration of single channel and dual channel. During reception, the IISRX0CTRL register is used to configure single channel or dual channel, and during transmission, the IISTX0CTRL register is used to configure single channel or dual channel;

3.6 Integrated Circuit Bus (IIC)

3.6.1 Brief introduction

The I2C interface is a bidirectional dual-wire synchronous serial bus that includes the SDA (Serial Data Line) and SCL (Serial Clock Line), both featuring open-drain outputs. This bus architecture enables communication between one or more master devices and one or more slave devices, where each connected device has a unique address. During any given time, only one master device can initiate access requests to a single slave device.

CI13322 supports 1 IIC. Its data frame format is usually composed of five parts: start signal, address signal, response signal, data signal and stop signal. It supports two modes: standard transmission rate of 100kbit/s and fast transmission rate of 400kbit/s.

3.6.2 Description of characteristics

- SDA: serial data line, two-way I/O line;
- SCL: serial clock line, provided by master;
- Support master and slave mode register configuration;
- Master: Starts the bus to transmit data and generates a clock when acting as a master device;
- Slave: A slave device that is addressed as a slave device and has a unique address;
- Starting signal: When SCL is high, SDA jumps from high to low, indicating the start of transmission;
- Address signal: supports 7-bit addressing mode, including 7-bit address bit and 1-bit read/write bit;
- Response signal: ACK for successful reception, NACK for failure or end of transmission;
- Data signal: transmitted by Byte, the MSB is sent first and the LSB is sent last;
- Stop signal: When SCL is high, SDA jumps from low level to high level, indicating the end of transmission;
- The bus transmission rate can be configured as standard-100kbit/s and fast-400kbit/s;

3.6.3 Sequence chart

The master initiates communication by generating the Start condition: When SCL is high, it pulls SDA low and transmits 8 clock pulses through SCL to transfer a Byte containing 7-bit address bits and 1-bit read/write bits. If the slave's address matches the transmitted 7-bit address, a response signal is generated. Both master and slave determine data transmission based on the read/write bits and conclude transmission by checking the logic level of the response bits. During data transfer, SDA changes only when SCL is low. Upon completing communication, the master sends the Stop condition to terminate transmission: When SCL is high, it pulls SDA high.

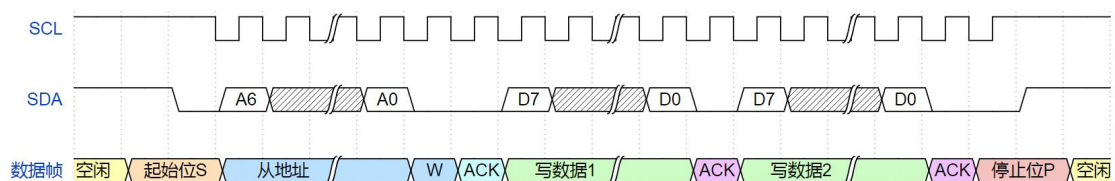

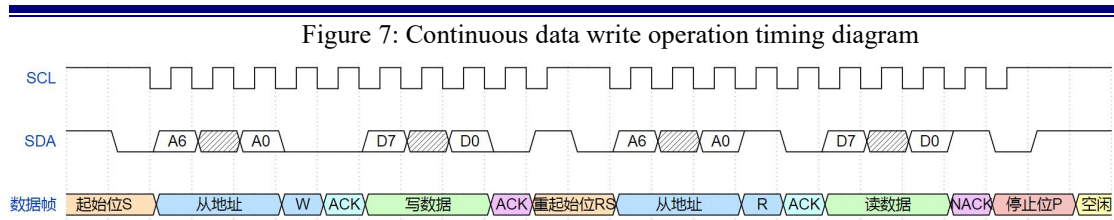

Figure 8: Write before read operation timing diagram

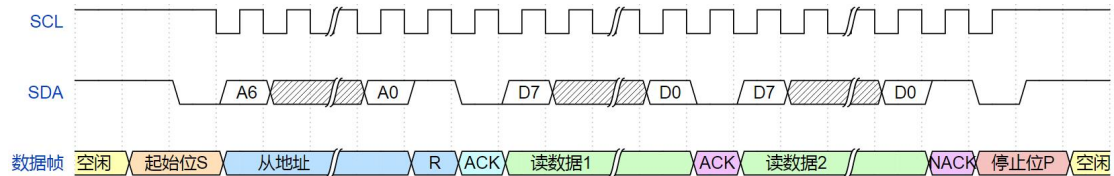

Figure 9: IIC read operation timing diagram

3.7 Independent Watchdog (IWDG)

3.7.1 Brief introduction

IWDG is a hardware timing circuit, which is mainly used to monitor the system faults caused by abnormal operation and recover from the faults.

3.7.2 Characteristic

CI13322 supports one IWDG module. IWDG is based on a 32-bit decrementing counter, which starts to decrement from the loaded value. When the count value reaches 0, a timeout interrupt is generated. The counter reloads the loaded value again, and when the count value reaches 0 again, if the timeout interrupt is not cleared, IWDG will generate a reset request.

The range of the reset field can be configured through the SYS_RESET_CFG register.

3.8 Multimedia audio and video codec (CODEC)

3.8.1 Brief introduction

CI13322 has built-in high-performance low-power audio CODEC, which

supports one ADC and one DAC. The analog signal input by MIC is amplified by PGA after MIC gain. This PGA can be controlled by ALC of CODEC itself, and digital gain can be amplified after PGA.

3.8.2 Characteristic

- DAC supports up to 24 bits, SNR up to 90dB;
- ADC supports up to 24 bits, SNR up to 90dB;
- Support single-ended, differential MIC input and line-in input;
- Support ALC automatic gain control;
- Sampling rate support: 8k/12k/16k/24k/32k/44.1k/48k;

3.9 Enhanced Pulse Width Modulation output (EPWM)

3.9.1 Brief introduction

EPWM (Enhanced Pulse Width Modulation output) is a more sophisticated pulse width modulation technology compared to conventional PWM, offering enhanced functionality and configuration options. It enables specialized functions such as reverse operation, chopping, low-level or high-level phase control, and is widely used in power control devices across industrial and consumer electronics applications, including motor control systems and switching power supplies.

Each EPWM consists of two PWM outputs, PWMN and PWMP, respectively. This pair of PWM outputs can be used as a normal PWM, complementary PWM wave output, or custom PWM output.

3.9.2 Characteristic

- A 16-bit counter with controllable frequency;
- Supports external or software to configure the start or end of a counter through the TBCTL register;
- Support for one to multiple PWM outputs: central symmetric PWM output; edge symmetric PWM output; edge asymmetric PWM output;
- Support initial phase configuration through TBPHS register;
- 16-bit dead time, which supports the delay time of rising edge or falling edge

through DBRED or DBFED registers;

- When the external brake command arrives, the PWM output can be configured as high level, low level and high resistance state through TZSEL register;

3.9.3 Description of configuration values

The core configuration parameters of EPWM include TBPRD, ZERO, CMPA and CMPB. Among them, TBPRD defines the period length of PWM wave, while CMPA and CMPB are used to set the duty cycle. By configuring these parameters, the frequency and duty cycle of PWM wave can be controlled.

- TBPRD: Count cycle value (>0), the maximum configuration width is 16 bits, and the action of pull high, pull low or unchanged is generated when the count is configured to TBPRD value through AQCTLA or AQCTLB register;
- ZERO: Counting cycle value ($=0$), which is configured by AQCTLA or AQCTLB register to generate pull high, pull low or unchanged actions when counting to ZERO value;
- CMPA: Count comparison value A, the maximum configuration width is 16 bits, and when the count is configured to CMPA value through AQCTLA or AQCTLB register, it generates pull high, pull low or unchanged actions;
- CMPB: Count comparison value B, the maximum configuration width is 16 bits. When the count is configured to CMPB value through AQCTLA or AQCTLB register, it generates actions such as pull high, pull low or unchanged;

3.9.4 Counting patterns

EPWM supports three counting modes: increment mode, decrement mode, and add/subtract mode. Different counting modes are suitable for different application scenarios.

- Increasing mode: The counter increases from 0 to TBPRD every cycle. One TBPRD cycle can output one PWM cycle, which can be configured through TBCTR register;
- Decrement mode: The counter decreases from TBPRD to 0 every cycle. One TBPRD cycle can output one PWM cycle, which can be configured through

TBCTR register;

- Add/subtract mode: The counter increases from 0 to TBPRD in odd cycles and decreases from TBPRD to 0 in even cycles. Two TBPRD cycles can output one PWM cycle, which can be configured through TBCTR register;

3.9.5 Usage method

EPWM can output various waveforms through configuration, including 50% duty cycle PWM waves and low-level duty cycle PWM waves. To generate the desired waveform, users must first configure the values of TBPRD, CMPA, and CMPB, specify their counting modes, and define the actions triggered when the counter reaches TBPRD, ZERO, CMPA, or CMPB thresholds. This configuration process allows three possible scenarios: $CMPA = CMPB$, $CMPA > CMPB$, or $CMPA < CMPB$.

4 electrical character

Table 3: Electrical characteristics table

Symbol	Description	Min.	Typical	Max.	Unit
VIN5V	Chip power input *Note1*	3.6	5	5.5	V
AVDD	3.3V power supply	2.97	3.3	3.63	V
VDD11	1.1V power supply	0.99	1.1	1.21	V
V_{IH}	Enter high voltage, $3.0V \leq V_{DD33} \leq 3.6V$	$0.7 \times V_{DD33}$	-	$V_{DD33} + 0.3$	V
V_{IL}	Input low voltage, $3.0V \leq V_{DD33} \leq 3.6V$	-0.3	-	$0.3 \times V_{DD33}$	V
V_{OL}	Output low voltage @IOL = 12mA	-	-	0.4	V
V_{OH}	Output high voltage @IOH = 20mA	2.4	-	-	V
I_{5VIO}	IO (5V withstand voltage) output 3.3V with drive current	20	-	33	mA
I_{33VIO}	IO(3.3V (Overvoltage) Output 3.3V drive current	14	-	24	mA
$\Sigma IVDD$	The total current of all IOs on the chip	-	-	260	mA
Pde	Using 5V power supply, the chip 1.1V is powered by an external DC-DC chip. The total power consumption of the 5V input during normal identification (environmental temperature TA = 25 °C)	40	-	90	mW
Pdi	The chip is powered by 5V and uses an internal PMU. The total power consumption of the 5V input is recognized normally (environmental temperature TA = 25 °C)	125	-	255	mW

RC Precision	TA = -40 to 85°C	-1.5	-	+1.5	%
T _A	The chip uses an internal RC oscillator to adapt to the operating temperature	-40	-	+85	°C
T _{ST}	Chip storage temperature	-55	-	+150	°C

5 Packaging information

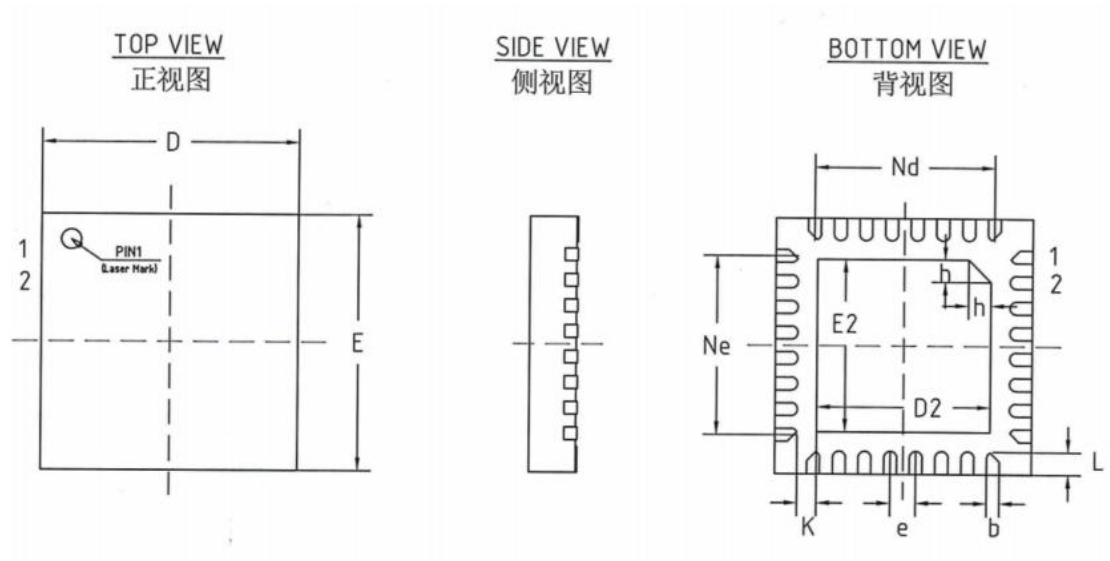

COMMON DIMENSIONS

SYMBOL	UNIT: MILLIMETER		
	MIN	NOM	MAX
A	0.70	0.75	0.80
A1	-	0.02	0.05
A2	-	0.203	-
b	0.15	0.20	0.25
D	3.9	4.00	4.10
D2	2.65	2.70	2.75
E	3.90	4.00	4.10
E2	2.65	2.70	2.75
e	0.40BSC		
K	0.25	0.30	0.35
h	0.30	0.35	0.40
L	0.30	0.35	0.40
Ne	2.80 BSC		
Nd	2.80 BSC		

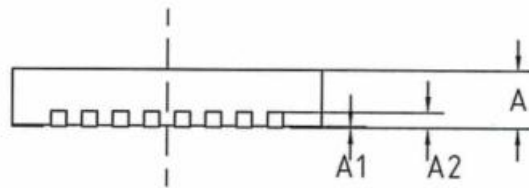

Figure 10: Package size

6 Order information

The MRAK of CI13322 chip package is shown in the figure below. The first line is the company LOGO, the second line is the chip model, the third line is the production batch number, and the dot in the lower left corner is the identification of pin 1.



The chip model is defined as follows:

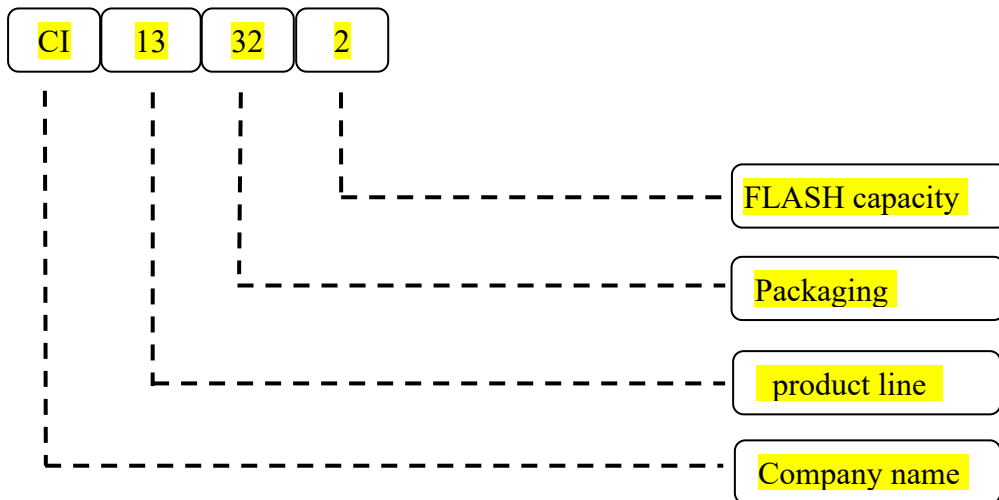

Table 4: Order Information Table

Chip module	Flash	Status	Package Type	Pins	Package Qty	Eco Plan	MSL	Op Temp (°C)
CI13322	2MByte	MP	QFN32/ roll	32	4,000 copies per volume	RoHS & Green	Level-3 260C-UNLIM	-40 to 85

7 Application program

7.1 Application reference circuit diagram

The CI1332Z chip requires minimal peripheral components to support various voice applications. For the audio section, it supports both single-microphone differential input and single-microphone unbalanced input configurations. Users can select appropriate circuitry based on their application's functional requirements, power consumption constraints, and cost considerations. Below is a detailed schematic diagram demonstrating the chip's simplest practical implementation.

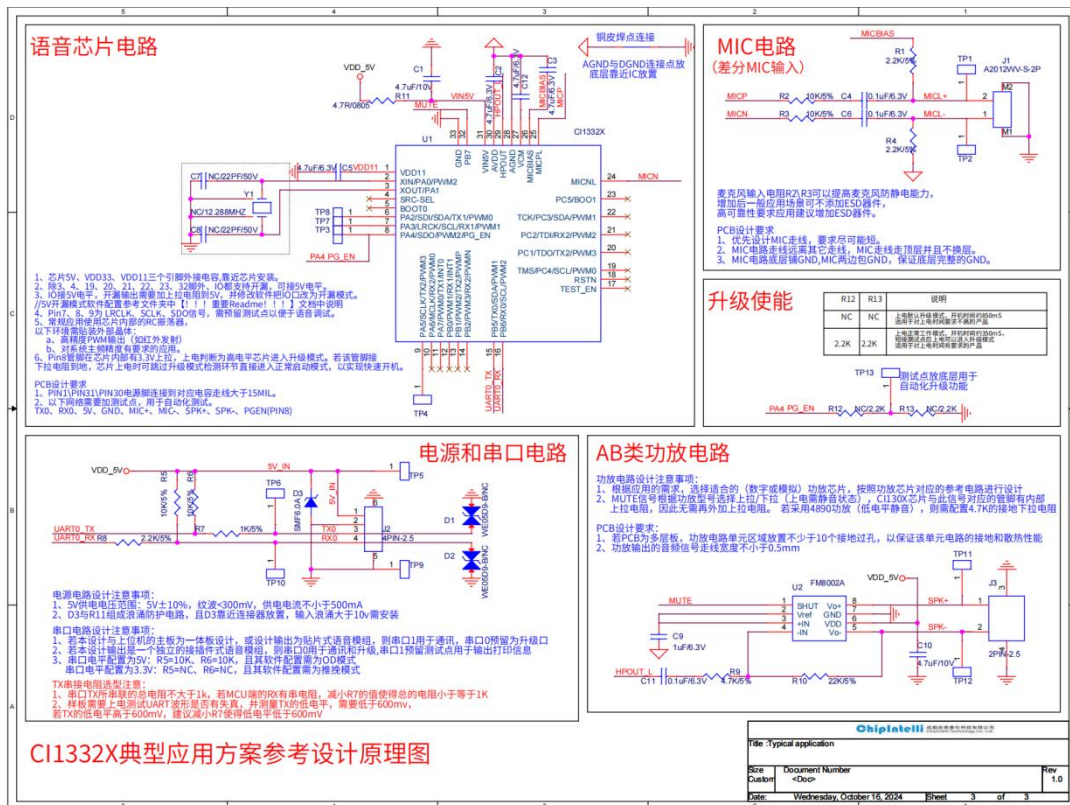

Figure 11: Reference circuit diagram of typical application solution of CI1332X

The figure above shows a typical application circuit diagram of a single microphone differential input and power amplifier output for the CI1332X series chips including CI1332Z. Users can design according to the corresponding peripheral device specifications in the figure above.

When designing the schematic, consider implementing board-level online upgrade functionality by routing UART0 pins. This allows firmware updates to the main chip's internal Flash memory via UART0 after PCB surface-mount assembly. The PA4 (PG_EN) pin is internally pulled-up by default, enabling upgrade mode upon power-on. The system detects external UART0 upgrade signals during startup and initiates updates if detected. The default boot time increases to

approximately 850ms due to the added upgrade mode detection. For critical boot time requirements, extend PA4 with two 2.2KΩ pull-down resistors grounded, creating a test node between them. This configuration enables normal boot mode with approximately 350ms, significantly reducing startup time. To enable online upgrades, externally apply high voltage to the test node between the 2.2KΩ resistors, pull up PA4, and then execute UART0 upgrades.

PG_EN external resistor diagram 1	Installation status of R21 and R13	PG_EN high and low levels	available machine time
	R12 and R13 are NC	High level, upgrade mode	850ms
	R12\R13 is 2.2K	Low level, working mode	350ms

Table 5: CI13322 upgrade mode table

The chip solution offers two design options: differential microphone and single-ended microphone. The differential microphone configuration shown in the diagram is recommended. For cost-sensitive applications, users may modify the microphone section to a single-ended design, which reduces passive components compared to differential configurations. However, this approach is only recommended for microphone cables shorter than 20 cm, as excessive cable length compromises interference resistance and voice recognition performance. The amplifier in the diagram employs Class AB amplification, with the 8002 chip being the recommended choice. Users can select alternative chips according to requirements, and the circuitry can be removed to reduce costs if amplification functionality is not required.

When users have no specific power consumption requirements for the solution, it is recommended to directly utilize the PMU (Power Management Unit) within the chip for power supply. If power consumption needs are specified, an external DC-DC converter can be added to provide 1.1V power to reduce energy consumption. All UART ports on the chip support 5V communication. The UART0 port in the diagram currently connects to a 3.3V signal. To achieve 5V operation, simply add pull-up resistors connected to the 5V source around the RX and TX pins of UART0 – no additional voltage conversion circuitry is required.

7.2 Use other precautions

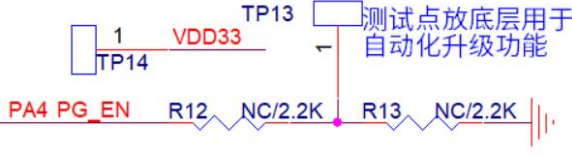
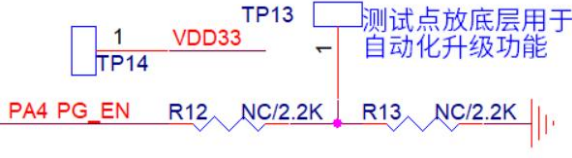
1. The built-in RC oscillator in the chip exhibits temperature drift ($\pm 1.5\%$) under extreme thermal conditions due to semiconductor technology limitations. The chip incorporates adaptive baud rate hardware that maintains stable communication with host computers across varying temperatures when enabled. For applications requiring higher clock precision, the CI1332X series chips should be paired with external crystal oscillators.
2. The chip integrates the PMU management unit, and the PMU contains two LDO to provide 3.3V and 1.1V voltage respectively for the chip. If there is no special requirement on power consumption, the solution does not need an external power supply chip, and the external 5V power supply ripple should be less than 300mV.
3. The chip is manufactured with lead-free environmental protection process. When SMT welding, please set the reflow temperature and time according to lead-free standard.

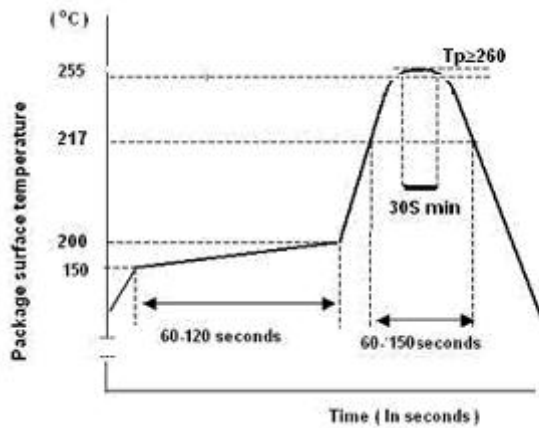

Figure 12: Furnace temperature curve

4. Attention should be paid to the effect of static electricity during chip use and packaging. It is recommended to use anti-static materials for isolation.

8 History of revision

Table 6: Revision history

RELEASE VERSION	AMENDED CONTENT	DATE OF REVISION
1.0	Initial version	2025.02.27
1.1	1、 Added a section on chip interface description	2025.06.26

- Chipintelli reserves the right to modify the instructions without prior notice. Customers should obtain the latest version of the information before placing an order and verify whether the relevant information is complete and up-to-date.
- Any semiconductor product has a certain possibility of failure or failure under specific conditions. The buyer is responsible for complying with safety standards and taking safety measures when using the product for system design and complete machine manufacturing, so as to avoid potential failure risks that may cause personal injury or property loss!
- Product improvement is endless, our company will be committed to provide customers with better products!